

V-Lock系统
The V-Lock system



V-Lock 系统包含了一系列特定的安装组件，通过这些组件可以将不同的自动化设备组合在一起，从而形成一个完整的方案。

The V-Lock system is a range of components for automation and fixing elements.

V-Lock 是一套符合标准的模块化连接系统，具有易于组装、快速配置的特点，该系统可提供两种选项模式：一种可确保精确的、可重复的连接，另一种则允许安装位置可以进行调节。这种标准化且通用的模块系统可使设计人员的工作更为轻松，因为不再需要额外设计适配器、法兰、支架等，他们可以专注于问题的核心部分，即机器的设计。同样，对于安装人员而言，由于该系统提供了一整套标准化、模块化的安装组件，因此可以在很短的时间内完成组装、设置以及重新配置机器等工作。

HžaU] X]Vfgd] Y S efS` VSd/ _aVg`SdUa` `WUf] Y ekefW_ t
V8ek SeeW_ T`k] dSb[V Ua` X]Ygd]ffa` t S` V
fZWab]ffa` aXW]fZVd]bdWU]eVd]NbV8fST`WUa` `WUf]a` e
adS` SV]ge]ST`W_ ag` f] Y baef]fa` žFZ[e efS` VSd/ S` V
g` [hV8eS^`_aVg`SdekefW_ _S]V8e fZWW]W8e]Y` Wde i ad
V8e]Vd]TWUSge]W]f[e` af` WUW8eSck f8 VV8e]Y` SVSbf8cd
XS` YW8 TdU] W8e S` V ea a` t S` V ZWUS` Ua` UW]f8fW
a` fZWZV8df aXfZWbcbT`W_ t` S_ Wk fZWW]W8e]Y` aXfZW
SUZ[V8e`-]W [e]W fZWb]W8e` i Za SeeW T`W8e fZW
Ua`_ba` W]e [e b8h[VW i [fZ S Ua`_b`W]W] [f fZSf [e cg[U]
S` V V8ek f8 ge]W ea fZW_ SUZ[WUS` TWSeeW_ T`W]t e]W
gb S` V d]W8a` X]Ygd]W [S` hV8k eZa`df]_ V8e

基本安装元件 Basic elements



V-Lock 固定元件
HžaU] X] [Y W]W_ W]e



V-Lock 连接件
HžaU] SVSbf8cd



型材
Bcb X]W8

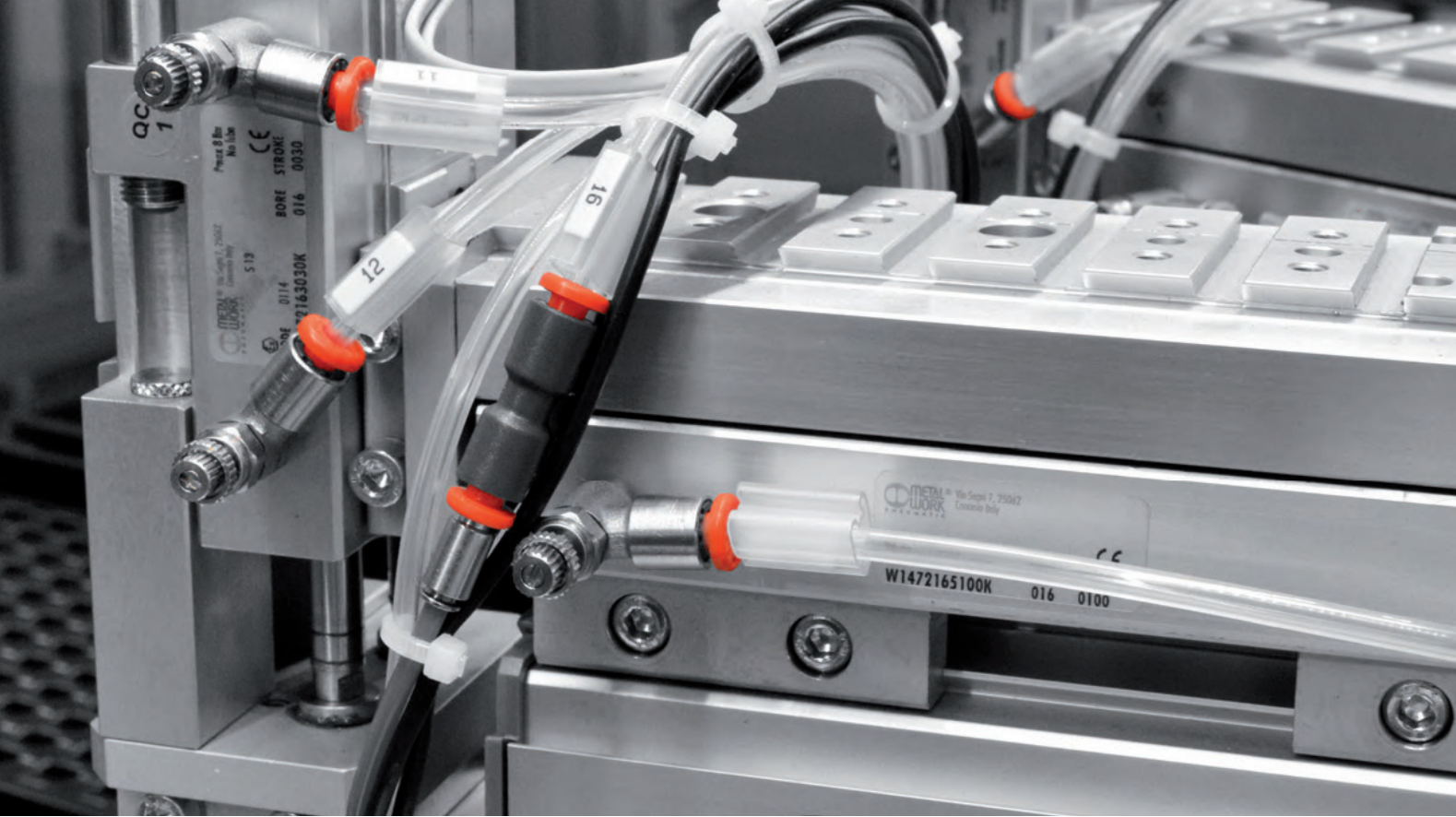

直线驱动器 Linear actuators



带循环滚珠导轨的 V-Lock 系列无杆缸
Rodless cylinder with ball recirculating guide Series V-Lock



紧凑型带导轨气缸
CMPGK系列
Compact guided cylinder Series CMPGK



直线驱动单元 LEPK系列
Linear units Series LEPK

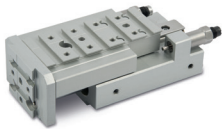

紧凑型精密滑台气缸
S14K系列
Compact precision slide Series S14K

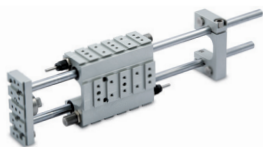

导向装置 GDHK 和 GDMK系列
Guide units Series GDHK and GDMK

旋转驱动器 Rotary actuators



旋转驱动器 R3K 系列
Rotary actuator Series R3K

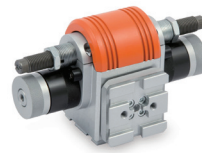

旋转驱动器 DAPK 系列
Rotary actuator Series DAPK

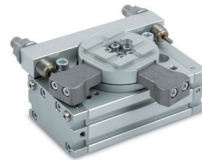

旋转驱动器 R3K系列，带外置液压缓冲
Rotary actuator Series R3K with external shock absorbers

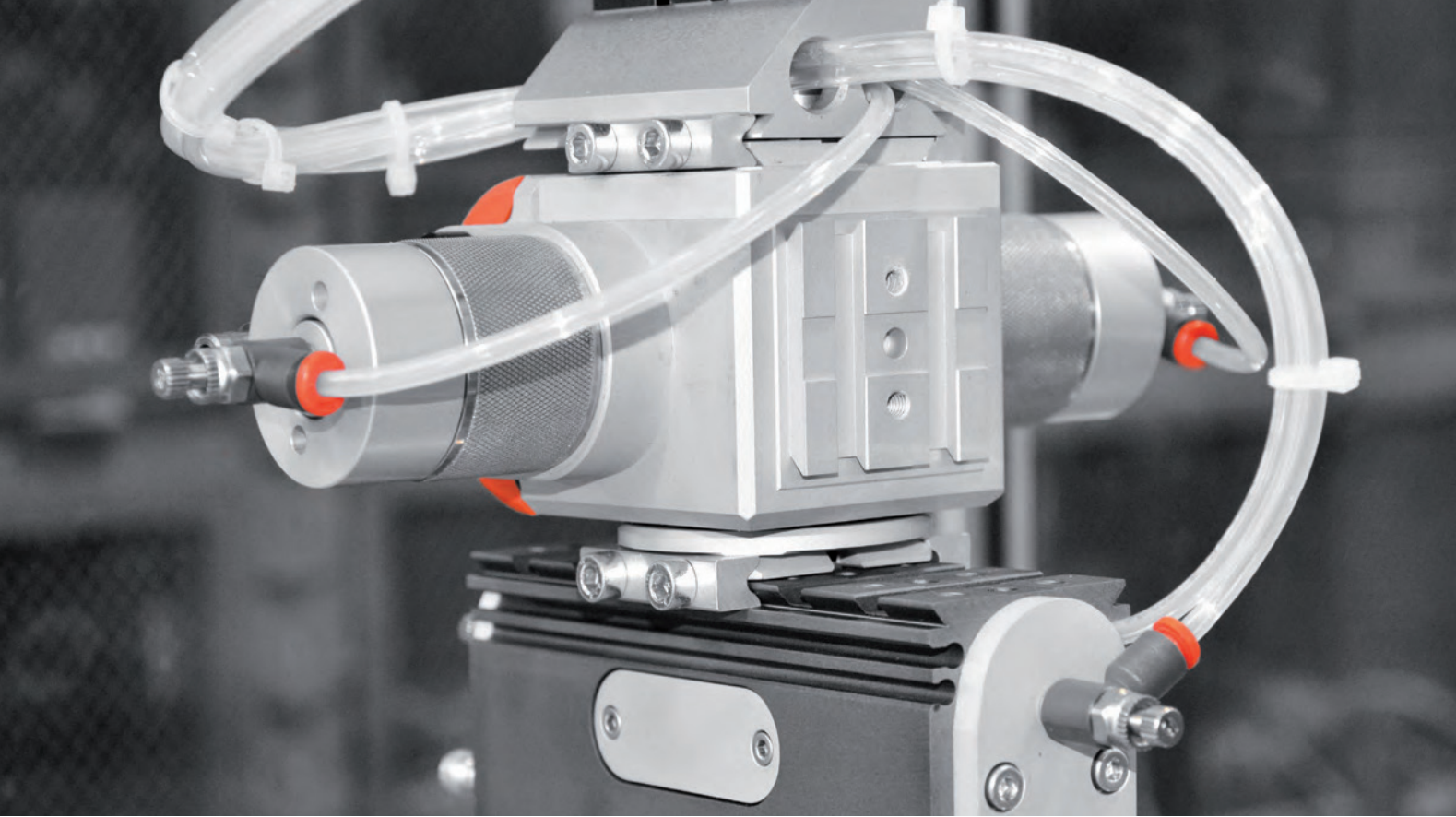

电缸

Electric axis system



Elektro SHAK系列电缸
Electric axis elektro Series SHAK

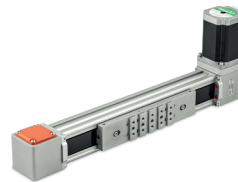

Asse elettrico senza stelo serie elektro BK
Electric axis - rodless elektro Series BK



ElektroVBK系列电缸
Cantilever electric axis elektro Series VBK



Asse elettrico serie elektro SHAK GANTRY
Electric axis Series elektro SHAK GANTRY



Elektro SVAK系列电缸
Cantilever electric axis elektro Series SVAK

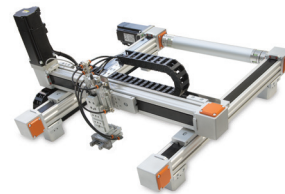

Asse elettrico serie elektro BK GANTRY
Electric axis Series elektro BK GANTRY



Elektro SK系列无杆电缸
Electric axis - rodless elektro Series SK

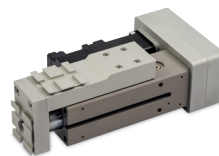

Slitta elettrica serie elektro CS
Electric slide Series elektro CS

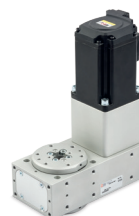

Attuatore elettrico rotante serie Elektro RBA
Electric rotary actuator Series elektro RBA

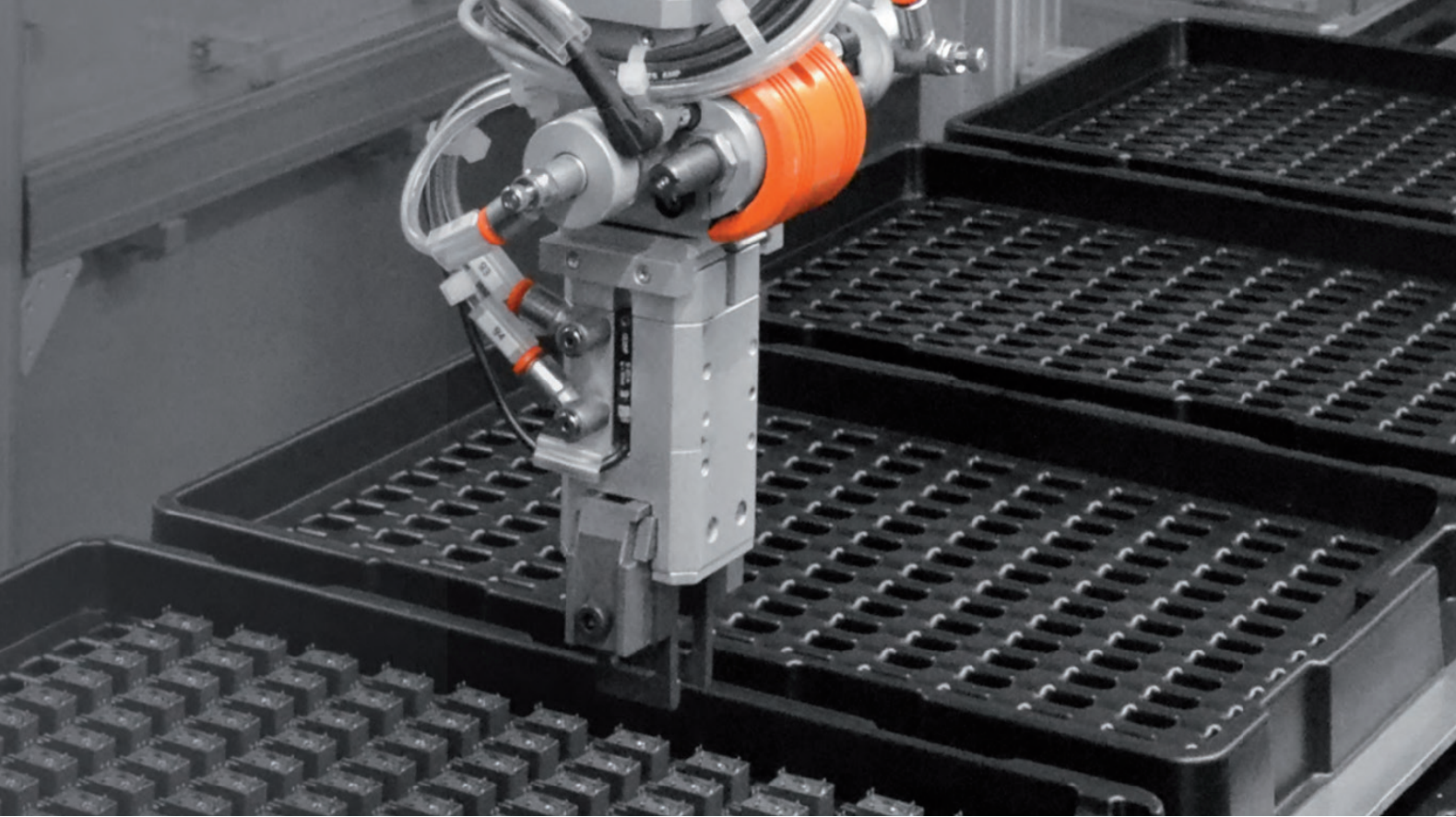

气爪 Gripper



带两个平行夹爪的气爪, P1K 系列
Gripper with two parallel jaws Series P1K



带两个平行夹爪的气爪, P2K 系列
Gripper with two parallel jaws Series P2K



带两个平行夹爪的气爪, P3K 系列
Gripper with two parallel jaws Series P3K

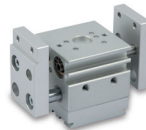

带两个平行长行程夹爪的气爪, P4K 系列
Gripper with two parallel jaws, long stroke Series P4K



带两个平行长行程夹爪的气爪, GPLK 系列
Gripper with two parallel jaws, long stroke Series GPLK



带两个铰接夹爪的气爪, P7K 系列
Gripper with two hinged jaws Series P7K



带两个轴接夹爪的气爪, 张角 180°, P9K 系列
Gripper 180° with two hinged jaws Series P9K

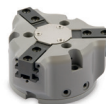

带三个平行夹爪的气爪, P12K 系列
Gripper with three parallel jaws Series P12K

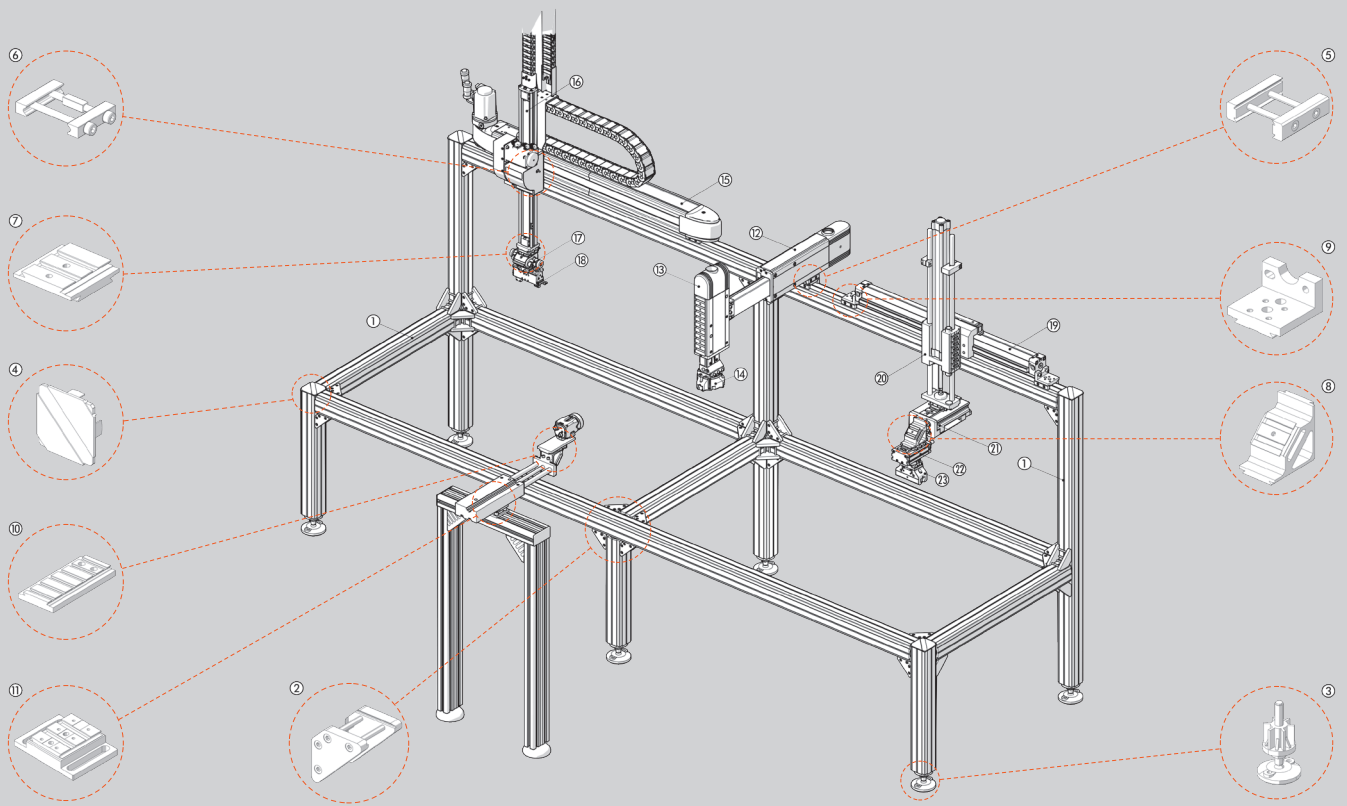

导览

通过 V-Lock 系统我们可以创建气动和/或电气自动化系统，其应用非常广泛，不论是简单的还是极其复杂的都能适用。

- 1 Quick-Set 系列带燕尾槽型材，直接使用型材切割刀就可按所需长度对型材进行切割；切割后的型材无需钻孔或加工销孔就可连接装配。相对 T-型沟槽连接，燕尾槽连接能承受更高的负载。
- 2 支架，用于固定 Quick-set 系列型材。
- 3 可调蹄脚，高度调节范围最大 90mm。
- 4 塑料端盖，用于型材末端。
- 5 QS 型紧固件，用于连接 V-Lock 型材和/或元件(元件的 V-Lock 燕尾槽连接面无需贯通沟槽)。
- 6 K 型紧固件，通常用于带贯通沟槽的 V-Lock 元件之间的连接。元件之间的连接更为紧凑且精密，在拆卸并重新装配时可重复定位。
- 7 平行或正交连接件，实现 V-Lock 元件之间的平行或 90° 度正交连接。
- 8 支架，实现 V-Lock 元件之间的 45° 或 90° 角轴向，纵向或正交连接。
- 9 各种 V-Lock 安装附件：脚架，法兰等。
- 10 V-Lock 转接板，通过转接板其他任意元件（如图示中的摄像机）都可转换为 V-Lock 元件。
- 11 型材连接板，用于将 V-Lock 元件固定到市面上的主流型材（如 Bosch®, Item® 等）上。
- 12 LEPK 系列直线驱动单元，具有高精度，高刚性，长寿命等特点。其行程可调，端位通过液压缓冲器吸收冲击动能。可提供 2 和 3 位置两种型式。
- 13 垂直安装型式的 LEPK 系列直线驱动单元，可选择带复位弹簧的型式以平衡滑块和工件的重量。
- 14 3-爪气爪。
- 15 带齿形带驱动或丝杆驱动，配置不同导轨和驱动系统的电缸。图中所示为 Elektro SHAK 340 系列齿形带驱动电缸。
- 16 悬臂结构的垂直安装电缸。图中所示为 Elektro SVAK 系列电缸。
- 17 气动精密旋转驱动器。图中所示为 DAPK 系列带 2 个可调角度的旋转驱动器。
- 18 精密气爪。图中所示为带两个长行程平行夹爪的 GPLK 系列气爪。
- 19 V-Lock 结构的带循环滚珠导轨的无杆气缸。
- 20 V-Lock 结构的导向装置，可用于 ISO 15552 系列气缸或 Elektro ISO 15552 系列电缸。
- 21 滑台气缸。图中所示为 S14K 紧凑型精密滑台气缸。
- 22 R3K 气动旋转驱动器，摆动角度可调，终止止动装置可选限位挡块或液压缓冲器。
- 23 各种形式的气爪。两个平行夹爪，两个铰接爪，两个轴接夹爪或三个平行夹爪的气爪。

Guide

The V-Lock system can be used to create pneumatic and/or electrical automation systems for a wide range of applications, from simple to more complex ones.

Quick-Set dovetail fixing PROFILES, which can be cut up using a standard die-cutter and do not require any particular machining; no threaded holes or pinholes are required. Dovetail fixing elements can withstand greater loads than those with T-grooves.

BRACKETS for fixing Quick-set profiles.

Articulated FEET with 90 mm adjustment length.

Plastic CAP for profiles.

QS FIXING ELEMENTS for the coupling of V-Lock profiles and/or components (no need for V-Lock transverse grooves).

K FIXING ELEMENTS for V-Lock couplings, using the transverse grooves of V-Lock components. They feature high precision, repeatability and space saving.

Parallel or crosswise ADAPTORS for the coupling of V-Lock components, e.g. rotated by 90 degrees.

BRACKETS for fixing at a 45° or 90° angle, longitudinal, transversal, cross.

Various V-Lock fixing ACCESSORIES: feet, flanges, etc.

V-Lock TRANSFORMERS fixed to any component (a video camera in the photo) converts it into a V-Lock component.

PROFILE ADAPTORS to secure any types of profile (Bosch®, Item® etc.) available from the trade into V-Lock components.

Pneumatically-controlled LINEAR UNITS SERIES LEPK, featuring high precision and rigidity, long life, adjustable strokes, cushioned end stop, 2 or 3 positions.

LINEAR UNITS SERIES LEPK FOR VERTICAL MOUNTING, featuring weight balance of the slide and the applied mass.

3-JAW GRIPPERS.

ELECTRIC AXES SERIES ELEKTRO with a toothed belt, a ball circulation screw, various guide and drive systems. The figure shows an electric axis in the Elektro SHAK 340 series.

ELECTRIC AXIS FOR VERTICAL APPLICATIONS. The figure shows an electric axis in the Elektro SVAK series.

Pneumatically-controlled PRECISION ROTARY ACTUATORS. The figure shows a DAPK actuator with 2 adjustable angles.

PRECISION GRIPPERS. The figure shows a parallel long-stroke two-jaw gripper in the GPLK series.

RODLESS CYLINDERS with a V-Lock ball circulation guide.

V-Lock GUIDE UNIT for ISO 15552 pneumatic cylinders or Elektro ISO 15552 electric cylinders.

SLIDES. The figure shows an S14K compact precision slide.

R3K pneumatic ROTARY ACTUATORS, with an adjustable angle, mechanical stopper hydraulic internal or external shock-absorbers.

GRIPPERS with two parallel jaws, two hinged jaws, toggle joint and three jaws.

